



**C NTECH**<sup>®</sup>  
ENGINEERED SOLUTIONS

# Corrugated Metal Pipe Design Guide

**C NTECH**<sup>®</sup>  
**(PIPE SOLUTIONS)**

# Corrugated Metal Pipe (CMP) Design Guide

## Table of Contents

### Drainage Pipe Selection

Introduction .....	3
Environment & Abrasion Guidelines / Reference Specifications .....	4
Usage Guide for Drainage Products .....	4
Product Dimensions and Hydraulics .....	5

### HEL-COR® Corrugated Steel Pipe

Height of Cover Tables .....	7
Handling Weights .....	10

### CORLIX® Corrugated Aluminum Pipe

Height of Cover Tables .....	11
Handling Weights .....	12

### ULTRA FLO®

Height of Cover Tables .....	13
Handling Weights .....	14

<b>Installation of CMP</b> .....	15
----------------------------------	----

### Miscellaneous

Smooth Cor™ .....	16
QUICK STAB® Joint .....	17
End Sections .....	18

## Durability Design Guide

Proper design of culverts and storm sewers requires structural, hydraulic and durability considerations. While most designers are comfortable with structural and hydraulic design, the mechanics of evaluating abrasion, corrosion and water chemistry to perform a durability design are not commonly found in most civil engineering handbooks.

The durability and service life of a drainage pipe installation is directly related to the environmental conditions encountered at the site and the type of materials and coatings from which the culvert is fabricated. Two principle causes of reduced service life in drainage pipe materials are corrosion and abrasion.

Service life can be affected by the corrosive action of the backfill in contact with the outside of a drainage pipe or more commonly by the corrosive and abrasive action of the flow in the invert of the drainage pipe. The design life analysis should include a check for both the water side and soil side environments to determine which is more critical— or which governs service life.

The potential for metal loss in the invert of a drainage pipe due to abrasive flows is often overlooked by designers and its effects are often mistaken for corrosion. An estimate for potential abrasion is required at each pipe location in order to determine the appropriate material and gage.

This manual is intended to guide specifiers through the mechanics of selecting appropriate drainage products to meet service life requirements. The information contained in the following pages is a composite of several national guidelines.



## Using the CMP Design Guide

The choice of material, gage and product type can be extremely important to service life. The following steps describe the procedure for selecting the appropriate drainage product, material and gage to meet a specific service life requirement.

### Design Sequence

1. Select pipe or structure based on hydraulic and clearance requirements. Use Tables 5 and 6 as reference for size limits and hydraulic properties of all drainage products.
2. Use Height of Cover tables for the chosen pipe or structure to determine the material gage required for the specific loading condition.
3. Use Table 1 to select the appropriate material for the site-specific environmental conditions. Whenever possible, existing installations of drainage structures along the same water course offer the most reliable estimate of long-term performance for specific environment conditions. In many cases, there will be more than one material that is appropriate for the project environmental conditions. Generally speaking, the metal material types increase in price as you move from top down on Table 1. Please contact your local Contech Sales Representative for pricing.
4. Use Table 2 to determine which abrasion level most accurately describes the typical storm event (2 year storm). The expected stream velocity and associated abrasion conditions should be based on a typical flow and not a 10 or 50-year design flood.
5. Use Table 3 to determine whether the structural gage for the selected material is sufficient for the design service life. If the structural gage is greater than or equal to the gage required for a particular abrasion condition and service life, use the structural gage. Conversely, if the structural gage is less than the gage required for a particular abrasion condition and service life, use the gage required by Table 3.

#### Note:

Both Contech round pipe and pipe-arch are available with either helical or annular corrugations. Contech HEL-COR pipe (helical corrugations) is furnished with continuous lock seams and annual re-rolled ends or non-rerolled ends. For 3"x1" and 5"x1" HEL-COR pipe-arch, we recommend non-rerolled ends with flat or dimpled bands and flat gaskets. Contech riveted pipe is furnished with annular corrugations only. The height of cover tables in this guide are helical corrugations only. Consult your Contech representative for Height of Cover tables on riveted pipe.

Material Type	Soil* and Water pH										Resistivity (ohm-cm)	
	3	4	5	6	7	8	9	10	11	12	Minimum	Maximum
Galvanized Steel*											2,000	10,000
Aluminized Steel Type 2 (ALT2)											1,500	N/A
Polymer-Coated											250	N/A
Aluminum Alloy											500	N/A

\*Appropriate pH range for Galvanized Steel is 6.0 to 10



Abrasion Level	Abrasion Condition	Bed Load	Flow Velocity (fps)
1	Non-Abrasive	None	Minimal
2	Low Abrasion	Minor	< 5
3	Moderate Abrasion	Moderate	5 - 15
4	Severe Abrasion	Heavy	> 15

"Interim Direct Guidelines on Drainage Pipe Alternative Selection." FHWA, 2005.

Application	Culverts, Storm Drain, Cross Drain, Median Drain, Side Drain											
Roadway Classification	Rural	Minor	Major	Urban	Rural	Minor	Major	Urban	Rural	Minor	Major	Urban
Design Service Life	25	50	75	100	25	50	75	100	25	50	75	100
Abrasion Level	Abrasion Level 1 & 2				Abrasion Level 3				Abrasion Level 4			
<b>CMP (1/2" &amp; 1" deep corrugations), ULTRA FLO® &amp; Smooth Cor™</b>												
Minimum gage required to meet design service life, assuming that structural design has been met.												
Galvanized (2 oz.)	16	12	10	8 <sup>4</sup>	14	10	8	N/A	14 <sup>5</sup>	10 <sup>5</sup>	8 <sup>5</sup>	N/A
Galvanized and Asphalt Coated	16	14	10	8	14	12	8	N/A	14 <sup>5</sup>	12 <sup>5</sup>	8 <sup>5</sup>	N/A
Galv., Asphalt Coated & Paved Invert	16	16	14	10	16	14	12	8	14	12	10	N/A
Aluminized Type 2 (ALT2)	16	16	16	14	14	14	14	12	14 <sup>6</sup>	14 <sup>6</sup>	14 <sup>6</sup>	12 <sup>6</sup>
Polymer-Coated	16	16	16 <sup>8</sup>	16 <sup>9</sup>	16	16	16 <sup>8</sup>	16 <sup>9</sup>	14 <sup>7</sup>	14 <sup>7</sup>	14 <sup>7,8</sup>	14 <sup>7,9</sup>
Aluminum Alloy	16	16	16	16	14	14	14	14	14 <sup>5</sup>	14 <sup>5</sup>	14 <sup>5</sup>	14 <sup>5</sup>

- Based on Table 1 - Recommended Environments.
- Smooth Cor™ Steel Pipe combines a corrugated steel exterior shell with a hydraulically smooth interior liner.
- Service life estimates for ULTRA FLO® and Smooth Cor™ Pipe assume a storm sewer application. Storm sewers rarely achieve abrasion levels 3 or 4. For applications other than storm sewers or abrasion conditions above Abrasion Level 2, please contact your Contech Sales Representative for gage and coating recommendations.
- Design service life for 8 GA galvanized is 97 years.
- Invert protection to consist of velocity reduction structures.
- Asphalt coated and paved invert or velocity reduction structures are needed.
- Requires a field applied concrete paved invert with minimum thickness 1" above corrugation crests.
- 75 year service life for polymer-coated is based on a pH range of 4-9 and resistivity greater than 750 ohm-cm.
- 100 year service life for polymer-coated is based on a pH range of 5-9 and resistivity greater than 1500 ohm-cm.

	Material Type	Material	Pipe	Design*	Installation*
<b>Pipe &amp; Pipe-Arch</b>	<b>CMP (1/2" or 1" deep corrugations)</b>				
	Galvanized (2 oz.)	M218	M36	Section 12	Section 26
	Asphalt Coated	M190	M36	Section 12	Section 26
	Asphalt Coated and Paved Invert	M190	M36	Section 12	Section 26
	Aluminized Type 2	M274	M36	Section 12	Section 26
	Polymer-Coated	M246	M36 & M245	Section 12	Section 26
	Aluminum Alloy	M197	M196	Section 12	Section 26
	<b>ULTRA FLO® (3/4" x 3/4" x 7-1/2" corrugation)</b>				
	Galvanized (2 oz.)	M218	M36	Section 12	Section 26
	Aluminized Type 2	M274	M36	Section 12	Section 26
	Polymer-Coated	M246	M36 & M245	Section 12	Section 26
	Aluminum Alloy	M197	M196	Section 12	Section 26
	<b>Smooth Cor™</b>				
	Polymer-Coated	M246	M36 & M245	Section 12	Section 26

\* AASHTO LRFD Bridge Design Specification and AASHTO Standard Specification for Highway Bridges

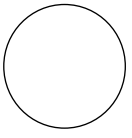
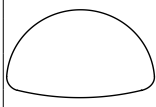
Table 5 - Product Dimensions					
	Drainage Product	Common Uses	Size Limits*		Manning's "n" Value
			Minimum	Maximum	
	Corrugated Steel (1/2" deep corrugation)	Culverts, small bridges, storm water detention/retention systems, conduits, tunnels, storm sewers.	12"	84"	0.011 - 0.021
	Corrugated Steel with Paved Invert (1/2" deep corrugation)		12"	84"	0.014 - 0.020
	Corrugated Steel (1" deep corrugation)		54"	144"	0.022 - 0.027
	Corrugated Steel with Paved Invert (1" deep corrugation)		54"	144"	0.019 - 0.023
	Corrugated Aluminum (1/2" deep corrugation)		12"	72"	0.011 - 0.021
	Corrugated Aluminum (1" deep corrugation)		30"	120"	0.023 - 0.027
	ULTRA FLO® Steel	Storm sewers, culverts, storm water detention/retention systems.	18"	102"	0.012
	ULTRA FLO® Aluminum		18"	84"	0.012
	Smooth Cor™ Steel (1/2" deep corrugation)		18"	66"	0.012
	Smooth Cor™ Steel (1" deep corrugation)		48"	126"	0.012
	Corrugated Steel (1/2" deep corrugation)	Culverts, small bridges, storm water detention/retention systems, conduits, tunnels, storm sewers.	17" x 13"	83" x 57"	0.011 - 0.021
	Corrugated Steel with Paved Invert (1/2" deep corrugation)		17" x 13"	83" x 57"	0.014 - 0.019
	Corrugated Steel (1" deep corrugation)		53" x 41"	142" x 91"	0.023 - 0.027
	Corrugated Steel with Paved Invert (1" deep corrugation)		53" x 41"	142" x 91"	0.019 - 0.022
	Corrugated Aluminum (1/2" deep corrugation)		17" x 13"	71" x 47"	0.011 - 0.021
	Corrugated Aluminum (1" deep corrugation)		60" x 46"	112" x 75"	0.023 - 0.027
	ULTRA FLO® Steel	Storm sewers, culverts, storm water detention/retention systems.	20" x 16"	66" x 51"	0.012
	ULTRA FLO® Aluminum		20" x 16"	66" x 51"	0.012
	Smooth Cor™ Steel (1/2" deep corrugation)		21" x 15"	77" x 52"	0.012
	Smooth Cor™ Steel (1" deep corrugation)		53" x 41"	137" x 87"	0.012

\* For sizes outside of these limits, please contact your Contech representative.

Table 6 — Corrugated Steel Pipe—Values of Coefficient of Roughness (Manning's "n")										
	Helical* Corrugation – 2 2/3" x 1/2"							1-1/2" x 1/4"		Annular
	12 in.	15 in.	18 in.	24 in.	36 in.	48 in.	60 in. +	8 in.	10 in.	
<b>2 2/3" x 1/2"</b>										<b>All Diameters</b>
Unpaved	0.011	0.012	0.013	0.015	0.018	0.020	0.021	0.012	0.014	0.024
Paved Invert				0.014	0.017	0.020	0.019			0.021
Smooth Cor™			0.012	0.012	0.012	0.012	0.012			N/A
	<b>Helical* – 3" x 1"</b>									<b>All Diameters</b>
<b>3" x 1"</b>	<b>36 in.</b>	<b>42 in.</b>	<b>48 in.</b>	<b>54 in.</b>	<b>60 in.</b>	<b>66 in.</b>	<b>72 in.</b>	<b>78 in. +</b>		<b>All Diameters</b>
Unpaved	0.022	0.022	0.023	0.023	0.024	0.025	0.026	0.027		0.027
Paved Invert	0.019	0.019	0.020	0.020	0.021	0.022	0.022	0.023		0.023
Smooth Cor™			0.012	0.012	0.012	0.012	0.012	0.012		N/A
	<b>Helical* – 5" x 1"</b>									<b>All Diameters</b>
<b>5" x 1"</b>			<b>48 in.</b>	<b>54 in.</b>	<b>60 in.</b>	<b>66 in.</b>	<b>72 in.</b>	<b>78 in. +</b>		<b>All Diameters</b>
Unpaved			0.022	0.022	0.023	0.024	0.024	0.025		N/A
Paved Invert			0.019	0.019	0.020	0.021	0.021	0.022		N/A
<b>ULTRA FLO®</b>	<b>3/4" x 3/4" x 7-1/2"</b>									N/A
	All diameters n = 0.012									

\* Tests on helically corrugated pipe demonstrate a lower coefficient of roughness than for annularly corrugated steel pipe. Pipe-arches have approximately the same roughness characteristics as their round equivalent pipes.

# Area and Hydraulic Radius for Corrugated Steel Pipe Flowing Full

Round Pipe – Area & Hydraulic Radius		
Diameter (in.)	Area (Ft <sup>2</sup> )	Hydraulic Radius (ft.)
12	0.8	0.250
15	1.2	0.312
18	1.8	0.375
21	2.4	0.437
24	3.1	0.500
30	4.9	0.625
36	7.1	0.750
42	9.6	0.875
48	12.6	1.000
54	15.9	1.125
60	19.6	1.250
66	23.8	1.375
72	28.1	1.500
78	33.2	1.625
84	38.5	1.750
90	44.2	1.875
96	50.3	2.000
102	56.8	2.125
108	63.6	2.250
114	70.9	2.375
120	78.5	2.500
126	86.6	2.625
132	95.0	2.750
138	103.9	2.875
144	113.1	3.000

Pipe-Arch – Area & Hydraulic Radius			
2 2/3" x 1/2" Corrugated Steel Pipe			
Diameter (in.)	Pipe-Arch Equivalent Size (in.)	Waterway Area (Ft <sup>2</sup> )	Hydraulic Radius A/πD (ft.)
15	17 x 13	1.1	0.280
18	21 x 15	1.6	0.340
21	24 x 18	2.2	0.400
24	28 x 20	2.4	0.462
30	35 x 24	4.5	0.573
36	42 x 29	6.5	0.690
42	49 x 33	8.9	0.810
48	57 x 38	11.6	0.924
54	64 x 43	14.7	1.040
60	71 x 47	18.1	1.153
66	77 x 52	21.9	1.268
72	83 x 57	26.0	1.380

Pipe-Arch – Area & Hydraulic Radius			
3" x 1" or 5" x 1" Corrugated Steel Pipe			
Diameter (in.)	Pipe-Arch Equivalent Size (in.)	Waterway Area (Ft <sup>2</sup> )	Hydraulic Radius A/πD (ft.)
54	60 x 46	15.6	1.104
60	66 x 51	19.3	1.230
66	73 x 55	23.2	1.343
72	81 x 59	27.4	1.454
78	87 x 63	32.1	1.573
84	95 x 67	37.0	1.683
90	103 x 71	42.4	1.800
96	112 x 75	48.0	1.911
102	117 x 79	54.2	2.031
108	128 x 83	60.5	2.141
114	137 x 87	67.4	2.259
120	142 x 91	74.5	2.373

**Notes:**

1. Listed pipe arch dimensions do not include tolerance.
2. For additional detail, please reference the hydraulic radius tables (Figure 4.32 and 4.33) found in the NCSA CSP Design Manual, 2008.

ULTRA FLO® Pipe-Arch – Area & Hydraulic Radius			
2 2/3" x 1/2" Corrugated Steel Pipe			
Diameter (in.)	Pipe-Arch Equivalent Size (in.)	Waterway Area (Ft <sup>2</sup> )	Hydraulic Radius A/πD (ft.)
18	20 x 16	1.7	0.36
21	23 x 19	2.3	0.42
24	27 x 21	3.0	0.48
30	33 x 26	4.7	0.60
36	40 x 31	6.7	0.71
42	46 x 36	9.2	0.84
48	53 x 41	12.1	0.96
54	60 x 46	15.6	1.10
60	66 x 51	19.3	1.23

# HEL-COR® Corrugated Steel Pipe

## Heights of Cover

### 2 2/3" x 1/2" Height of Cover Limits for Corrugated Steel Pipe

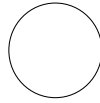

#### H 20 and H 25 Live Loads

Diameter (in.)	Minimum Cover (in.)	Maximum Cover <sup>(2)</sup> (ft.)					
		Specified Thickness (in.) and Gage					
		(0.052) 18	(0.064) 16	(0.079) 14	(0.109) 12	(0.138) 10	(0.168) 8
6 <sup>(8)</sup>	12	388	486				
8 <sup>(8)</sup>	12	291	365				
10 <sup>(8)</sup>	12	233	292				
12	12	197	248	310			
15	12	158	198	248			
18	12	131	165	206			
21	12	113	141	177	248		
24	12	98	124	155	217		
30	12		99	124	173		
36	12		83	103	145	186	
42	12		71	88	124	159	195
48	12		62	77	108	139	171
54	12			67	94	122	150
60	12				80	104	128
66	12				68	88	109
72	12					75	93
78	12						79
84	12						66

#### H 20 and H 25 Live Loads, Pipe-Arch

Size		Minimum Thickness (in.)	Minimum Cover (in.)	Maximum Cover (ft.)
Round Equivalent (in.)	Span x Rise (in.)			2 Tons/Ft. <sup>2</sup> Corner Bearing Pressure
15	17 x 13	0.064	12	16
18	21 x 15	0.064	12	15
21	24 x 18	0.064	12	15
24	28 x 20	0.064	12	15
30	35 x 24	0.064	12	15
36	42 x 29	0.064	12	15
42	49 x 33	0.064*	12	15
48	57 x 38	0.064*	12	15
54	64 x 43	0.079*	12	15
60	71 x 47	0.109*	12	15
66	77 x 52	0.109*	12	15
72	83 x 57	0.138*	12	15

#### E 80 Live Loads

Diameter (in.)	Minimum Cover (in.)	Maximum Cover <sup>(2)</sup> (ft.)					
		Specified Thickness (in.) and Gage					
		(0.052) 18	(0.064) 16	(0.079) 14	(0.109) 12	(0.138) 10	(0.168) 8
12	12	197	248	310			
15	12	158	198	248			
18	12	131	165	206			
21	12	113	141	177	248		
24	12	98	124	155	217		
30	12		99	124	173		
36	12		83	103	145	186	
42	12		71	88	124	159	195
48	12		62	77	108	139	171
54	18			67	94	122	150
60	18				80	104	128
66	18				68	88	109
72	18					75	93
78	24						79
84	24						66

#### E 80 Live Loads, Pipe-Arch

Size		Minimum Thickness (in.)	Minimum Cover (in.)	Maximum Cover (ft.)
Round Equivalent (in.)	Span x Rise (in.)			3 Tons/Ft. <sup>2</sup> Corner Bearing Pressure
15	17 x 13	0.079	24	22
18	21 x 15	0.079	24	22
21	24 x 18	0.109	24	22
24	28 x 20	0.109	24	22
30	35 x 24	0.138	24	22
36	42 x 29	0.138	24	22
42	49 x 33	0.138*	24	22
48	57 x 38	0.138*	24	22
54	64 x 43	0.138*	24	22
60	71 x 47	0.138*	24	22

\* These values are based on the AISI Flexibility Factor limit (0.0433 x 1.5) for pipe-arch.

#### Heights of Cover Notes:

1. These tables are for lock-seam or welded-seam construction. They are not for riveted construction. Consult your Contech Sales Representative for Height of Cover tables on riveted pipe.
2. These values, where applicable, were calculated using a load factor of K=0.86 as adopted in the NCSPA CSP Design Manual, 2008.
3. The haunch areas of a pipe-arch are the most critical zone for backfilling. Extra care should be taken to provide good material and compaction to a point above the spring line.
4. E 80 minimum cover is measured from top of pipe to bottom of tie.
5. H 20 and H 25 minimum cover is measured from top of pipe to bottom of flexible pavement or top of rigid pavement.
6. The pipe-arch tables are based on the corner bearing pressures as shown. These values may increase or decrease with changes in allowable corner bearing pressures. Consider the use of a round pipe in cases where the height of cover exceeds 8'.

7. For construction loads, see Page 15.
8. 1-1/2" x 1/4" corrugation. H 20, H 25 and E 80 loading.
9. Smooth Cor™ has same Height of Cover properties as corrugated steel pipe. The exterior shell of Smooth Cor™ is manufactured in either 2 2/3" x 1/2" or 3" x 1" corrugations; maximum exterior shell is 12 GA.

## Heights of Cover

### 5" x 1" or 3" x 1" Height of Cover Limits for Corrugated Steel Pipe

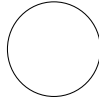

#### H 20 and H 25 Live Loads

Diameter (in.)	Minimum Cover (in.)	Maximum Cover (ft.)				
		Specified Thickness (in.) and Gage				
		(0.064) 16	(0.079) 14	(0.109) 12	(0.138) 10	(0.168) 8
54	12	56	70	98	127	155
60	12	50	63	88	114	139
66	12	46	57	80	103	127
72	12	42	52	74	95	116
78	12	39	48	68	87	107
84	12	36	45	63	81	99
90	12	33	42	59	76	93
96	12	31	39	55	71	87
102	18	29	37	52	67	82
108	18		35	49	63	77
114	18		32	45	58	72
120	18		30	42	54	66
126	18			39	50	61
132	18			36	46	58
138	18			33	43	53
144	18				39	49

Maximum cover heights shown are for 5" x 1".  
To obtain maximum cover for 3" x 1", increase these values by 12%.

#### E 80 Live Loads

Diameter or Span (in.)	Minimum Cover (in.)	Maximum Cover (ft.)				
		Specified Thickness (in.) and Gage				
		(0.064) 16	(0.079) 14	(0.109) 12	(0.138) 10	(0.168) 8
54	18	56	70	98	127	155
60	18	50	63	88	114	139
66	18	46	57	80	103	127
72	18	42	52	74	95	116
78	24	39	48	68	87	107
84	24	36	45	63	81	99
90	24	33 <sup>(1)</sup>	42	59	76	93
96	24	31 <sup>(1)</sup>	39	55	71	87
102	30	29 <sup>(1)</sup>	37	52	67	82
108	30		35	49	63	77
114	30		32 <sup>(1)</sup>	45	58	72
120	30		30 <sup>(1)</sup>	42	54	66
126	36			39	50	61
132	36			36	46	58
138	36			33 <sup>(1)</sup>	43	53
144	36				39	49

Maximum cover heights shown are for 5" x 1".  
To obtain maximum cover for 3" x 1", increase these values by 12%.  
(1) These diameters in these gages require additional minimum cover.

#### Heights of Cover Notes:

- These tables are for lock-seam or welded-seam construction. They are not for riveted construction. Consult your Contech Sales Representative for Height of Cover tables on riveted pipe.
- These values, where applicable, were calculated using a load factor of  $K=0.86$  as adopted in the NCSA CSP Design Manual, 2008.
- The span and rise shown in these tables are nominal. Typically the actual rise that forms is greater than the specified nominal. This actual rise is within the tolerances as allowed by the AASHTO & ASTM specifications. The minimum covers shown are more conservative than required by the AASHTO and ASTM specifications to account for this anticipated increase in rise. Less cover height may be tolerated depending upon actual rise of supplied pipe-arch.
- The haunch areas of a pipe-arch are the most critical zone for backfilling. Extra care should be taken to provide good material and compaction to a point above the spring line.
- E 80 minimum cover is measured from top of pipe to bottom of tie.
- H 20 and H 25 minimum cover is measured from top of pipe to bottom of flexible pavement or top of rigid pavement.
- The pipe-arch tables are based on the corner bearing pressures as shown. These values may increase or decrease with changes in allowable corner bearing pressures. Consider the use of a round pipe in cases where the height of cover exceeds 8'.
- For construction loads, see Page 15.
- Smooth Cor™ has same Height of Cover properties as corrugated steel pipe. The exterior shell of Smooth Cor™ is manufactured in either 2 2/3" x 1/2" or 3" x 1" corrugations; maximum exterior shell is 12 GA.

### 5" x 1" Pipe-Arch Height of Cover Limits for Corrugated Steel Pipe



#### H 20 and H 25 Live Loads

Round Equivalent (in.)	Size		Minimum Thickness (in.)	Minimum Cover (in.)	Maximum Cover (ft.)
	Nominal				
	Min. Span (in.)	Max. Rise (in.)			
54	60 -2.7	46 +2.7	0.109	18	21
60	66 -3.0	51 +3.0	0.109	18	21
66	73 -3.3	55 +3.3	0.109	18	21
72	81 -3.6	59 +3.6	0.109	18	21
78	87 -4.4	63 +4.4	0.109	18	20
84	95 -4.8	67 +4.8	0.109	18	20
90	103 -5.2	71 +5.2	0.109	18	20
96	112 -5.6	75 +5.6	0.109	21	20
102	117 -5.9	79 +5.9	0.109	21	19
108	128 -6.4	83 +6.4	0.109	24	19
114	137 -6.9	87 +6.9	0.109	24	19
120	142 -7.1	91 +7.1	0.138	24	19

Larger sizes are available in some areas of the United States. Check with your local Contech representative. Negative and positive numbers listed with span and rise dimensions are negative and positive tolerances, no tolerance in opposite direction.

#### E 80 Live Loads, Pipe-Arch

Round Equivalent (in.)	Size		Minimum Thickness (in.)	Minimum Cover (in.)	Maximum Cover (ft.)
	Nominal				
	Min. Span (in.)	Max. Rise (in.)			
54	60 -2.7	46 +2.7	0.109	30	21
60	66 -3.0	51 +3.0	0.109	30	21
66	73 -3.3	55 +3.3	0.109	30	21
72	81 -3.6	59 +3.6	0.109	30	21
78	87 -4.4	63 +4.4	0.109	30	18
84	95 -4.8	67 +4.8	0.109	30	18
90	103 -5.2	71 +5.2	0.109	36	18
96	112 -5.6	75 +5.6	0.109	36	18
102	117 -5.9	79 +5.9	0.109	36	17
108	128 -6.4	83 +6.4	0.109	42	17
114	137 -6.9	87 +6.9	0.109	42	17
120	142 -7.1	91 +7.1	0.138	42	17

Some 3" x 1" and 5" x 1" minimum gages shown for pipe-arch are due to manufacturing limitations. Negative and positive numbers listed with span and rise dimensions are negative and positive tolerances, no tolerance in opposite direction.



## Heights of Cover

### 3" x 1" Pipe-Arch Height of Cover Limits for Corrugated Steel Pipe-Arch

#### H 20 and H 25 Live Loads



Round Equivalent (in.)	Size		Minimum Thickness (in.)	Minimum Cover (in.)	Maximum Cover (ft.)
	Nominal				
	Min. Span (in.)	Max. Rise (in.)			
48	53 -2.4	41 +2.4	0.079	12	25
54	60 -2.7	46 +2.7	0.079	15	25
60	66 -3.0	51 +3.0	0.079	15	25
66	73 -3.3	55 +3.3	0.079	18	24
72	81 -3.6	59 +3.6	0.079	18	21
78	87 -4.4	63 +4.4	0.079	18	20
84	95 -4.8	67 +4.8	0.079	18	20
90	103 -5.2	71 +5.2	0.079	18	20
96	112 -5.6	75 +5.6	0.079	21	20
102	117 -5.9	79 +5.9	0.109	21	19
108	128 -6.4	83 +6.4	0.109	24	19
114	137 -6.9	87 +6.9	0.109	24	19
120	142 -7.1	91 +7.1	0.138	24	19

Larger sizes are available in some areas of the United States. Check with your local Contech Sales Representative. Negative and positive numbers listed with span and rise dimensions are negative and positive tolerances, no tolerance in opposite direction.

#### Heights of Cover Notes:

1. These tables are for lock-seam or welded-seam construction. They are not for riveted construction. Consult your Contech Sales Representative for Height of Cover tables on riveted pipe.
2. These values, where applicable, were calculated using  $K=0.86$  as adopted in the NCSA CSP Design Manual, 2008.
3. The span and rise shown in these tables are nominal. Typically the actual rise that forms is greater than the specified nominal. This actual rise is within the tolerances as allowed by the AASHTO & ASTM specifications. The minimum covers shown are more conservative than required by the AASHTO and ASTM specifications to account for this anticipated increase in rise. Less cover height may be tolerated depending upon actual rise of supplied pipe-arch.
4. The haunch areas of a pipe-arch are the most critical zone for backfilling. Extra care should be taken to provide good material and compaction to a point above the spring line.
5. E 80 minimum cover is measured from top of pipe to bottom of tie.
6. H 20 and H 25 minimum cover is measured from top of pipe to bottom of flexible pavement or top of rigid pavement.
7. The pipe-arch tables are based on the corner bearing pressures as shown. These values may increase or decrease with changes in allowable corner bearing pressures. Consider the use of a round pipe in cases where the height of cover exceeds 8'.
8. For construction loads, see Page 15.
9. Smooth Cor™ has same Height of Cover properties as corrugated steel pipe. The exterior shell of Smooth Cor™ is manufactured in either 2 2/3" x 1 1/2" or 3" x 1" corrugations; maximum exterior shell is 12 GA.

#### E 80 Live Loads, Pipe-Arch

Round Equivalent (in.)	Size		Minimum Thickness (in.)	Minimum Cover (in.)	Maximum Cover (ft.)
	Nominal				
	Min. Span (in.)	Max. Rise (in.)			
48	53 -2.4	41 +2.4	0.079	24	25
54	60 -2.7	46 +2.7	0.079	24	25
60	66 -3.0	51 +3.0	0.079	24	25
66	73 -3.3	55 +3.3	0.079	30	24
72	81 -3.6	59 +3.6	0.079	30	21
78	87 -4.4	63 +4.4	0.079	30	18
84	95 -4.8	67 +4.8	0.079	30	18
90	103 -5.2	71 +5.2	0.079	36	18
96	112 -5.6	75 +5.6	0.079	36	18
102	117 -5.9	79 +5.9	0.109	36	17
108	128 -6.4	83 +6.4	0.109	42	17
114	137 -6.9	87 +6.9	0.109	42	17
120	142 -7.1	91 +7.1	0.138	42	17

Some 3" x 1" and 5" x 1" minimum gages shown for pipe-arch are due to manufacturing limitations. Negative and positive numbers listed with span and rise dimensions are negative and positive tolerances, no tolerance in opposite direction.



# Approximate Weight (lbs/ft)

## HEL-COR® Corrugated Steel Pipe

(Estimated Average Weights—Not for Specification Use)

1 1/2" x 1/4" Corrugation			
Inside Diameter (in.)	Specified Thickness (in.)	Galvanized & ALT2	Asphalt Coated
6	0.052	4	5
	0.064	5	6
8	0.052	5	6
	0.064	6	7
10	0.052	6	7
	0.064	7	8

Steel Thicknesses by Gage						
Gage (GA)	18	16	14	12	10	8
Thickness	.052	.064	.079	.109	.138	.168

2 2/3" x 1/2" Corrugation					
Inside Diameter (in.)	Specified Thickness (in.)	Galvanized & ALT2	Asphalt Coated	Asphalt Coated w/ Paved Invert	Smooth Cor™
12	0.052	8	10	13	
	0.064	10	12	15	
	0.079	12	14	17	
15	0.052	10	13	16	
	0.064	12	15	18	
	0.079	15	18	21	
18	0.052	12	16	19	
	0.064	15	19	22	25
	0.079	18	22	25	28
21	0.052	14	18	23	
	0.064	17	21	26	29
	0.079	21	25	30	33
24	0.109	29	33	33	41
	0.052	15	20	26	
	0.064	19	24	30	30
30	0.079	24	29	35	38
	0.109	33	38	44	47
	0.064	24	30	36	42
36	0.079	30	36	42	48
	0.109	41	47	53	59
	0.064	29	36	44	51
42	0.079	36	43	51	58
	0.109	49	56	64	71
	0.138	62	69	77	
48	0.064	34	42	51	60
	0.079	42	50	59	68
	0.109	57	65	74	82
54	0.138	72	80	89	
	0.168	88	96	105	
	0.064	38	48	57	67
60	0.079	48	58	67	77
	0.109	65	75	84	94
	0.138	82	92	101	
66	0.168	100	110	119	
	0.079	54	65	76	87
	0.109	73	84	95	106
72	0.138	92	103	114	
	0.168	112	123	134	
	0.109	81	92	106	117
78	0.138	103	114	128	
	0.168	124	135	149	
	0.109	89	101	117	129
84	0.138	113	125	141	
	0.168	137	149	165	
	0.138	123	137	154	(2)
84	0.168	149	163	180	
	0.168	161	177	194	(2)
84	0.168	173	190	208	(2)

3" x 1" or 5" x 1" Corrugation					
Inside Diameter (in.)	Specified Thickness (in.)	Galvanized & ALT2	Asphalt Coated	Asphalt Coated w/ Paved Invert	Smooth Cor™
54	0.064	50	66	84	84
	0.079	61	77	95	95
	0.109	83	100	118	118
	0.138	106	123	140	
	0.168	129	146	163	
60	0.064	55	73	93	93
	0.079	67	86	105	105
	0.109	92	110	130	130
	0.138	118	136	156	
	0.168	143	161	181	
66	0.064	60	80	102	102
	0.079	74	94	116	116
	0.109	101	121	143	145
	0.138	129	149	171	
	0.168	157	177	199	
72	0.064	66	88	111	112
	0.079	81	102	126	127
	0.109	110	132	156	157
	0.138	140	162	186	
	0.168	171	193	217	
78	0.064	71	95	121	120
	0.079	87	111	137	136
	0.109	119	143	169	168
	0.138	152	176	202	
	0.168	185	209	235	
84	0.064	77	102	130	130
	0.079	94	119	147	147
	0.109	128	154	182	181
	0.138	164	189	217	
	0.168	199	224	253	
90	0.064	82	109	140	139
	0.079	100	127	158	157
	0.109	137	164	195	194
	0.138	175	202	233	
	0.168	213	240	271	
96	0.064	87	116	149	148
	0.079	107	136	169	168
	0.109	147	176	209	208
	0.138	188	217	250	
	0.168	228	257	290	
102	0.064	93	124	158	158
	0.079	114	145	179	179
	0.109	155	186	220	222
	0.138	198	229	263	
	0.168	241	272	306	
108	0.079	120	153	188	189
	0.109	165	198	233	235
	0.138	211	244	279	
	0.168	256	289	324	
	0.079	127	162	199	200
114	0.109	174	209	246	248
	0.138	222	257	294	
	0.168	271	306	343	
	0.079	134	171	210	211
	0.109	183	220	259	260
120	0.138	234	271	310	
	0.168	284	321	360	
	0.109	195	233	274	276
	0.138	247	285	326	
	0.168	299	338	378	
126	0.109	204	244	287	289
	0.138	259	299	342	
	0.168	314	354	397	
132	0.109	213	255	300	300
	0.138	270	312	357	
	0.168	328	370	415	
138	0.138	282	326	373	
	0.168	344	388	435	(2)

- Weights for polymer-coated pipe are 1% to 4% higher, varying by gage.
- Please contact your Contech Sales Representative.
- Weights listed in the 3" x 1" or 5" x 1" table are for 3" x 1" pipe. Weights for 5" x 1" are approximately 12% less than those used in this table, for metallic coated pipe.

# CORLIX® Corrugated Aluminum Pipe

## Heights of Cover

### 2 2/3" X 1/2" Height of Cover Limits for Corrugated Aluminum Pipe

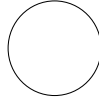

#### HL 93 Live Load

Diameter (in.)	Minimum Cover (in.)	Maximum Cover (ft.)					
		Specified Thickness (in.) and Gage					
		(0.048) 18	(0.060) 16	(0.075) 14	(0.105) 12	(0.135) 10	(0.164) 8
6 <sup>(4)</sup>	12	197	247				
8 <sup>(4)</sup>	12	147	185				
10 <sup>(4)</sup>	12	119	148				
12	12		125	157			
15	12		100	125			
18	12		83	104			
21	12		71	89			
24	12		62	78	109		
27	12			69	97		
30	12			62	87		
36	12			51	73	94	
42	12				62	80	
48	12				54	70	85
54	15				48	62	76
60	15					52	64
66	18						52
72	18						43

### 2 2/3" x 1/2" Height of Cover Limits for Corrugated Aluminum Pipe-Arch



#### HL 93 Live Load

Size		Minimum Gage	Minimum Cover (in.)	Maximum Cover (ft.)
Round Equivalent (in.)	Span x Rise (in.)			2 Tons/Ft.² for Corner Bearing Pressures
15	17 x 13	16	12	13
18	21 x 15	16	12	12
21	24 x 18	16	12	12
24	28 x 20	14	12	12
30	35 x 24	14	12	12
36	42 x 29	12	12	12
42	49 x 33	12	15	12
48	57 x 38	10	15	12
54	64 x 43	10	18	12
60	71 x 47	8 <sup>(5)</sup>	18	12

#### Notes:

1. Height of cover is measured to top of rigid pavement or to bottom of flexible pavement.
2. Maximum cover meets AASHTO LRFD design criteria.
3. Minimum cover meets AASHTO and ASTM B 790 design criteria.
4. 1 1/2" x 1/4" corrugation.
5. 8 GA pipe has limited availability.
6. For construction loads, see page 15.
7. Consult your Contech Sales Representative for E 80 Live Loads.

## Heights of Cover

### 3" x 1" Height of Cover Limits for Corrugated Aluminum Pipe

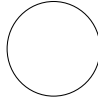

#### HL 93 Live Load

Diameter (in.)	Minimum Cover (in.)	Maximum Cover (ft.)				
		Specified Thickness (in.) and Gage				
		(0.060) 16	(0.075) 14	(0.105) 12	(0.135) 10	(0.164) 8
30	12	57	72	101	135	159
36	12	47	60	84	112	132
42	12	40	51	72	96	113
48	12	35	44	62	84	99
54	15	31	39	55	74	88
60	15	28	35	50	67	79
66	18	25	32	45	61	72
72	18	23	29	41	56	66
78	21		27	38	51	61
84	21			35	48	56
90	24			33	44	52
96	24			31	41	49
102	24				39	46
108	24				37	43
114	24					39
120	24					36

### 3" x 1" Height of Cover Limits for Corrugated Aluminum Pipe-Arch



#### HL 93 Live Load

Size		Minimum Gage	Minimum Cover (in.)	Maximum Cover (ft.)
Round Equivalent (in.)	Span x Rise (in.)			2 Tons/Ft.² for Corner Bearing Pressures
54	60 x 46	14	15	20
60	66 x 51	14	18	20
66	73 x 55	14	21	20
72	81 x 59	12	21	16
78 <sup>(4)</sup>	87 x 63	12	24	16
84 <sup>(4)</sup>	95 x 67	12	24	16
90 <sup>(4)</sup>	103 x 71	10	24	16
96 <sup>(4)</sup>	112 x 75	8 <sup>(5)</sup>	24	16

#### Notes:

1. Height of cover is measured to top of rigid pavement or to bottom of flexible pavement.
2. Maximum cover meets AASHTO LRFD design criteria.
3. Minimum cover meets ASTM B 790 design criteria.
4. Limited availability on these sizes.
5. 8 GA pipe has limited availability.
6. For construction loads, see page 15.
7. Consult your Contech Sales Representative for E 80 Live Loads.

# Approximate Weight/Foot CORLIX® Corrugated Aluminum Pipe

(Estimated Average Weights—Not for Specification Use)

2 2/3" x 1/2" Corrugation Aluminum Pipe						
Diameter (in.)	Weight (Lb./Lineal Ft.) <sup>1</sup>					
	Specified Thickness (in.) and Gage					
	(0.048) 18	(0.060) 16	(0.075) 14	(0.105) 12	(0.135) 10	(0.164) 8
6 <sup>(2)</sup>	1.3	1.6				
8 <sup>(2)</sup>	1.7	2.1				
10 <sup>(2)</sup>	2.1	2.6				
12		3.2	4.0			
15		4.0	4.9			
18		4.8	5.9			
21		5.6	6.9			
24		6.3	7.9	10.8		
27			8.8	12.2		
30			9.8	13.5		
36			11.8	16.3	20.7	
42				19.0	24.2	
48				21.7	27.6	33.5
54				24.4	31.1	37.7
60					34.6	41.9
66						46.0
72						50.1

3" x 1" Corrugation Aluminum Pipe					
Diameter (in.)	Weight (Lb./Lineal Ft.) <sup>1</sup>				
	Specified Thickness (in.) and Gage				
	(0.060) 16	(0.075) 14	(0.105) 12	(0.135) 10	(0.164) 8
30	9.3	11.5	15.8	20.2	24.5
36	11.1	13.7	18.9	24.1	29.3
42	12.9	16.0	22.0	28.0	34.1
48	14.7	18.2	25.1	32.0	38.8
54	16.5	20.5	28.2	35.9	43.6
60	18.3	22.7	31.3	40.0	48.3
66	20.2	24.9	34.3	43.7	53.0
72	22.0	27.1	37.4	47.6	57.8
78		29.3	40.4	51.5	62.5
84			43.5	55.4	67.2
90			46.6	59.3	71.9
96			49.6	63.2	76.7
102				66.6	80.8
108				71.0	86.1
114					90.9
120					95.6

**Notes:**

1. Helical lockseam pipe only. Annular riveted pipe weights will be higher.
2. 1 1/2" x 1/4" Corrugation.
3. 8 GA pipe has limited availability.



# ULTRA FLO®

## Heights of Cover

### Galvanized, ALUMINIZED STEEL Type 2 or Polymer-Coated\*\* Steel ULTRA FLO® H 20 and H 25 Live Load

Diameter (in.)	Minimum/Maximum Cover (ft.)			
	Specified Thickness (in.) and Gage			
	(0.064) 16	(0.079) 14	(0.109) 12	(0.138) 10
18	1.0 / 108	1.0 / 151		
21	1.0 / 93	1.0 / 130	1.0 / 216	
24	1.0 / 81	1.0 / 113	1.0 / 189	
30	1.0 / 65	1.0 / 91	1.0 / 151	
36	1.0 / 54	1.0 / 75	1.0 / 126	
42	1.0 / 46	1.0 / 65	1.0 / 108	
48	1.0 / 40	1.0 / 56	1.0 / 94	1.0 / 137
54	1.25 / 36	1.25 / 50	1.0 / 84	1.0 / 122
60	1.25*/32*	1.25 / 45	1.0 / 75	1.0 / 109
66		1.5 / 41	1.25 / 68	1.25 / 99
72		1.5*/37*	1.25 / 63	1.25 / 91
78		1.75*/34*	1.5 / 58	1.5 / 84
84			1.75 / 54	1.75 / 78
90			2.0*/50*	2.0 / 73
96			2.0*/47*	2.0 / 68
102			2.5*/43*	2.5 / 61
108				2.5*/54*
114				2.5*/49*
120				2.5*/43*

### Galvanized, ALUMINIZED STEEL Type 2 or Polymer-Coated\*\* Steel ULTRA FLO® E 80 Live Load

Diameter (in.)	Minimum/Maximum Cover (ft.)			
	Specified Thickness (in.) and Gage			
	(0.064) 16	(0.079) 14	(0.109) 12	(0.138) 10
18	1.0 / 93	1.0 / 130		
21	1.0 / 79	1.0 / 111	1.0 / 186	
24	1.0 / 69	1.0 / 97	1.0 / 162	
30	1.0 / 55	1.0 / 78	1.0 / 130	
36	1.5 / 46	1.25 / 65	1.0 / 108	
42	1.5 / 39	1.5 / 55	1.25 / 93	
48	2.0 / 34	1.75 / 48	1.5 / 81	1.5 / 118
54	3.0* / 28*	2.0 / 43	1.5 / 72	1.5 / 104
60		2.0 / 39	1.75 / 65	1.75 / 94
66		2.5* / 35*	2.0 / 58	2.0 / 85
72			2.0 / 49	2.0 / 78
78			2.5 / 42	2.5 / 72
84			2.75* / 35*	2.5 / 67
90				2.5 / 62
96				2.5* / 58*
102				3.0* / 52*

#### Notes:

- The tables for Steel H 20 and H 25 loading are based on the NCSPA Design Manual, 2008 and were calculated using a load factor of K=0.86. The tables for Steel E 80 loading are based on the AREMA Manual. The tables for Aluminum HL 93 loading are based on AASHTO LRFD Design Criteria.
- The haunch areas of a pipe-arch are the most critical zone for backfilling. Extra care should be taken to provide good material and compaction to a point above the spring line.
- E 80 minimum cover is measured from top of pipe to bottom of tie.
- H 20, H 25 and HL 93 minimum cover is measured from top of pipe to bottom of flexible pavement or top of rigid pavement.
- The pipe-arch tables are based on the corner bearing pressures as shown. These values may increase or decrease with changes in allowable corner bearing pressures. Consider the use of a round pipe in cases where the height of cover exceeds 8'.
- Larger size pipe-arches may be available on special order.
- M.L. (Heavier gage is required to prevent crimping at the haunches.)
- For construction loads, see Page 15.
- Sewer gage (trench conditions) tables for corrugated steel pipe can be found in the AISI book "Modern Sewer Design," 4th Edition, 1999. These tables may reduce the minimum gage (GA) due to a higher flexibility factor allowed for a trench condition.

### Galvanized, ALUMINIZED STEEL Type 2 or Polymer-Coated\*\* Steel ULTRA FLO® Pipe-Arch H 20 and H 25 Live Load

Round Equivalent (in.)	Size Span x Rise (in.)	Minimum/Maximum Cover (ft.)		
		Specified Thickness (in.) and Gage		
		(0.064) 16	(0.079) 14	(0.109) 12
18	20 x 16	1.0 / 16		
21	23 x 19	1.0 / 15		
24	27 x 21	1.0 / 13		
30	33 x 26	1.0 / 13	1.0 / 13	
36	40 x 31	1.0 / 13	1.0 / 13	
42	46 x 36	M.L. <sup>7</sup>	M.L. <sup>7</sup>	1.0 / 13
48	53 x 41	M.L. <sup>7</sup>	M.L. <sup>7</sup>	1.25 / 13
54	60 x 46	M.L. <sup>7</sup>	M.L. <sup>7</sup>	1.25 / 13
60	66 x 51	M.L. <sup>7</sup>	M.L. <sup>7</sup>	1.25 / 13

### Galvanized, ALUMINIZED STEEL Type 2 or Polymer-Coated\*\* Steel ULTRA FLO® Pipe-Arch E 80 Live Load

Round Equivalent (in.)	Size Span x Rise (in.)	Minimum/Maximum Cover (ft.)	
		Specified Thickness (in.) and Gage	
		(0.064) 16	(0.109) 12
18	20 x 16	2.0 / 22	
21	23 x 19	2.0 / 21	
24	27 x 21	2.0 / 18	
30	33 x 26	2.0 / 18	
36	40 x 31	2.0 / 17	
42	46 x 36		2.0 / 18
48	53 x 41		2.0 / 18
54	60 x 46		2.0 / 18
60	66 x 51		2.0 / 18



Polymer-coated ULTRA FLO® provides added durability.

- All heights of cover are based on trench conditions. If embankment conditions exist, there may be restriction on gages for the large diameters. Your Contech Sales Representative can provide further guidance for a project in embankment conditions.
- All steel ULTRA FLO® is installed in accordance with ASTM A798 "Installing Factory-Made Corrugated Steel Pipe for Sewers and Other Applications."
  - \* These sizes and gage combinations are installed in accordance with ASTM A796 paragraphs 18.2.3 and ASTM A798. For aluminum ULTRA FLO® refer to ASTM B790 and B788.
  - \*\* Contact your local Contech representative for more specific information on Polymer-Coated ULTRA FLO® for 12 GA and 10 GA.
  - \*\*\*Consult your Contech Sales Representative for E 80 Live Loads for Aluminum ULTRA FLO®.

## Heights of Cover

### Aluminum ULTRA FLO® HL 93 Live Load

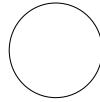

Diameter (in.)	Minimum/Maximum Cover (ft.) Specified Thickness (in.) and Gage			
	(0.060) 16	(0.075) 14	(0.105) 12	(0.135) 10
	18	1.0/43	1.0/61	
21	1.0/38	1.0/52	1.0/84	
24	1.0/33	1.0/45	1.0/73	
30	1.25/26	1.25/36	1.25/58	
36	1.5*/21*	1.50/30	1.5/49	1.5/69
42		1.75*/25*	1.75/41	1.75/59
48			2.0/36	2.0/51
54			2.0/32	2.0/46
60			2.0*/29*	2.0/41
66				2.0/37
72				2.5*/34*

### Aluminum ULTRA FLO® Pipe-Arch HL 93 Live Load



Size		Minimum/Maximum Cover (ft.) Specified Thickness (in.) and Gage			
		(0.060) 16	(0.075) 14	(0.105) 12	(0.135) 10
Round Equivalent (in.)	Span x Rise (in.)				
18	20 x 16	1.0/16			
21	23 x 19	1.0/15			
24	27 x 21	1.25/13	1.25/13		
30	33 x 26	1.5/13	1.5/13	1.5/13	
36	40 x 31		1.75/13	1.75/13	
42	46 x 36			2.0/13	2.0/13
48	53 x 41			2.0/13	2.0/13
54	60 x 46			2.0*/13*	2.0/13
60	66 x 51				2.0/13

See previous page for height of cover notes.

## Approximate Weight/Foot Contech ULTRA FLO® Pipe

### Handling Weight for ALUMINIZED STEEL Type 2 or Galvanized Steel ULTRA FLO®

Diameter (in.)	Weight (Pounds/Lineal Foot) Specified Thickness (in.) and Gage			
	(0.064) 16	(0.079) 14	(0.109) 12	(0.138) 10
	18	15	18	
21	17	21	29	
24	19	24	36	
30	24	30	42	
36	29	36	50	
42	33	42	58	
48	38	48	66	80
54	45	54	75	90
60	48	60	83	99
66		66	91	109
72		72	99	119
78		78	108	129
84			116	139
90			124	149
96			132	158
102			141	168
108				175
114				196
120				206

### Handling Weight for ALUMINUM ULTRA FLO®

Diameter (in.)	Weight (Pounds/Lineal Foot) Specified Thickness (in.) and Gage			
	(0.060) 16	(0.075) 14	(0.105) 12	(0.135) 10
	18	5	6	
21	6	8	11	
24	7	9	13	
30	9	11	15	
36	11	13	18	23
42		15	21	26
48			24	30
54			27	34
60			30	37
66				41
72				45

Weights for polymer-coated pipe are 1% to 4% higher, varying by gage.



ULTRA FLO® is available in long lengths, and its light weight allows it to be unloaded and handled with small equipment.



Reduced excavation due to the smaller outside diameter of ULTRA FLO®.

# Installation of CMP

## Overview

Satisfactory site preparation, trench excavation, bedding and backfill operations are essential to develop the strength of any flexible conduit. In order to obtain proper strength while preventing settlement, it is necessary that the soil envelope around the pipe be of good granular material, properly placed and carefully compacted.

## Bedding

Bedding preparation is critical to both pipe performance and service life. The bed should be constructed to uniform line and grade to avoid distortions that may create undesirable stresses in the pipe and/or rapid deterioration of the roadway. The bed should be free of rock formations, protruding stones, frozen lumps, roots and other foreign matter that may cause unequal settlement.

## Placing the pipe

Corrugated metal pipe weighs much less than other commonly used drainage structures. This is due to the efficient strength of the metal, further improved with carefully designed and formed corrugations. Even the heaviest sections of Contech pipe can be handled with relatively light equipment compared with equipment required for much heavier reinforced concrete pipe.

## Backfill

Satisfactory backfill material, proper placement and compaction are key factors in obtaining maximum strength and stability. Backfill should be a well-graded granular material and should be free of large stones, frozen lumps and other debris.

Backfill materials should be placed in layers about six inches deep, deposited alternately on opposite sides of the pipe. Each layer should be compacted carefully. Select backfill is placed and compacted until minimum cover height is reached, at which point, standard road embankment backfill procedures are used.

## Installation References

For more information, see AASHTO Bridge Construction Specification Section 26, the Installation Manual of the National Corrugated Steel Pipe Association, ASTM A798 for steel and ASTM B788 for aluminum ULTRA FLO®.

## Additional Considerations for ULTRA FLO® Installations Bedding and Backfill

Typical ULTRA FLO® installation requirements are the same as for any other corrugated metal pipe installed in a trench. Bedding and backfill materials for ULTRA FLO® follow the requirements of the CMP installation specifications mentioned above, and must be free from stones, frozen lumps or other debris. When ASTM A796 (steel) or B790 (aluminum) designs are to be followed for condition III requirements, indicated by asterisk (\*) in the tables on page 13 and 14, use clean, easily compacted granular backfill materials.

## Embankment Conditions

ULTRA FLO® is a superior CMP storm sewer product that is normally installed in a trench condition. In those unusual embankment installation conditions, pipe sizes and gages may be restricted. Your Contech Sales Representative can provide you with further guidance.

## Construction Loads

For temporary construction vehicle loads, an extra amount of compacted cover may be required over the top of the pipe. The Height of Cover shall meet minimum requirements shown in the table below. The use of heavy construction equipment necessitates greater protection for the pipe than finished grade cover minimums for normal highway traffic.

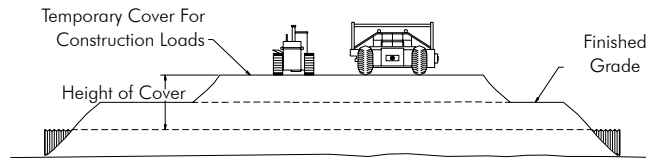

Min. Height of Cover Requirements for Construction Loads				
HEL-COR® Corrugated Steel Pipe*				
Diameter (in.)	Minimum Cover (ft.) for Indicated Axle Loads (kips)			
	18-50	50-75	75-110	110-150
12-42	2.0	2.5	3.0	3.0
48-72	3.0	3.0	3.5	4.0
78-120	3.0	3.5	4.0	4.0
126-144	3.5	4.0	4.5	4.5

Min. Height of Cover Requirements for Construction Loads				
CORLIX® Corrugated Aluminum Pipe*				
Diameter (in.)	Minimum Cover (ft.) for Indicated Axle Loads (kips)			
	18-50	50-75	75-110	110-150
12-42	3.0	3.5	4.0	4.0
48-72	4.0	4.0	5.0	5.5
78-120	4.0	5.0	5.5	5.5

Min. Height of Cover Requirements for Construction Loads				
ULTRA FLO® Pipe*				
Diameter (in.)	Minimum Cover (ft.) for Indicated Axle Loads (kips)			
	18-50	50-75	75-110	110-150
	Steel 3/4" x 3/4" x 7-1/2"			
15-42	2.0	2.5	3.0	3.0
48-72	3.0	3.0	3.5	4.0
78-108	3.0	3.5	4.0	4.5
	Aluminum 3/4" x 3/4" x 7-1/2"			
15-42	3.0	3.5	4.0	4.0

\* Minimum cover may vary depending on local conditions. The contractor must provide the additional cover required to avoid damage to the pipe. Minimum cover is measured from the top of the pipe to the top of the maintained construction roadway surface.

# Smooth Cor™ Pipe

## Excellent Hydraulics, Long Lengths and Easy Installation

### Corrugated Steel Shell

Smooth Cor pipe has a smooth interior steel liner that provides a Manning’s “n” of 0.012. Its rugged, corrugated steel shell supplies the structural strength to outperform rigid pipe. Smooth Cor pipe is both the economical and performance alternate to concrete.

### Superior hydraulics

Smooth Cor, with its smooth interior surface, is hydraulically superior to conventional corrugated steel pipe and with fewer joints and better interior surface, outperforms reinforced concrete pipe.

Smooth Cor, with its long lengths, light weight and beam strength, is superior to concrete pipe in many difficult situations such as poor soils, poor subsurface drainage conditions, steep slopes and high fills. Smooth Cor should be specified as an alternate under normal site conditions, and specified exclusively under very difficult situations that demand the strength of CSP with positive joints and a hydraulically efficient smooth liner.

### Two Pipe Shapes

In addition to full-round pipe, Smooth Cor comes in a pipe-arch shape for limited headroom conditions. The low, wide pipe-arch design distributes the flow area horizontally, enabling it to be installed with lower head room than a round pipe.

## Structural Design

### Reference specifications

<b>Material</b>	Polymer-Coated	ASTM A 929 AASHTO M246 ASTM A 742
<b>Pipe</b>	Polymer	AASHTO M245 ASTM A 762 & A 760
<b>Design</b>	Steel Pipe	AASHTO Section 12 ASTM A 796
<b>Installation</b>	Steel Pipe	AASHTO Section 26 ASTM A 798

Smooth Cor is lined with either 18 or 20 gage (GA) steel. Contech has taken a conservative approach to the Height of Cover. The maximum heights of cover are based on the shell thickness with no additional structural allowance for the liner as provided for in the AASHTO and ASTM design specifications. Using this approach, the Height of Cover tables for 2 2/3" x 1/2" and 3" x 1" steel corrugations can be used for Smooth Cor.

### Diameters

Smooth Cor is available in diameters ranging from 18 inches to 66 inches in 2 2/3" x 1/2" corrugation. The 3" x 1" corrugation is available in diameters of 48" to 126".

Pipe-arch sizes range from 21" x 15" through 77" x 52" for 2 2/3" x 1/2" corrugations, and 53" x 41" through 137" x 87" for 3" x 1" corrugations.

### Materials

Smooth Cor is available with a heavy-gage polymer coating that allows the engineer to design for long service life. This coating is a tough, heavy-gage polymer film laminated to both sides of the steel coil, providing a barrier to corrosion and mild abrasion which is particularly effective for protection in corrosive soils.

### Fittings

Smooth Cor can be fabricated into any type of structure including tees, elbows, laterals, catch basins, manifolds and reducers. Pre-fabricated fittings are more economical and have superior hydraulic characteristics when compared to concrete structures.

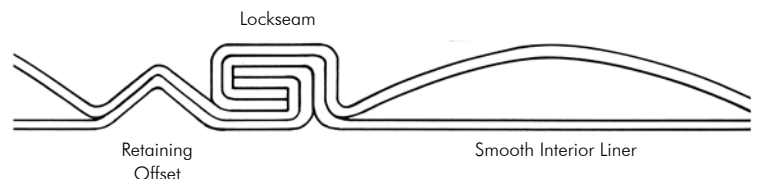



# QUICK STAB® Joint

## Save Time and Money With Faster Pipe Bell and Spigot Coupling

The Contech QUICK STAB Bell and Spigot joint speeds installation of corrugated metal pipe (CMP), reducing your costs. With the QUICK STAB coupling system, installation of CMP storm sewers and culverts has never been easier or faster.

The QUICK STAB joint creates a bell and spigot joining system with the bell only 1-1/2" larger than the pipe's O.D. Assembled at the factory, the QUICK STAB bell is shipped to the job site ready for installation. The only field operation is placing a special fluted gasket onto the spigot end of the pipe, applying lubricant and pushing it into the bell end of the preceding pipe. Without bands, bolts and wrenches to work and worry with, you can join pipe segments 50% to 90% faster—saving time, money and aggravation.

## Soil Tight Joint

Contech's QUICK STAB joint provides the same soil tightness as conventional CMP bands. Each QUICK STAB joint uses a double sealing fluted gasket to seal the spigot against the bell. A flat gasket is installed at the plant between the pipe and the corrugated end of the bell. With the deep bell, you gain maximum soil tightness with minimal installation effort.

## Wide Variety of Coatings and Materials

- Plain galvanized
- Aluminized Steel Type 2 (ALT2)
- Aluminum
- Polymeric coated

## Four Times Faster Installation Than Concrete

The QUICK STAB's bell and spigot joining system allows pipe segments to be joined quicker than reinforced concrete pipe. Next, add in Contech's corrugated metal pipe's length advantage—each segment is four times longer than standard concrete pipe lengths. That means fewer joints and faster installation—up to four times faster! Plus, with the bell only 1-1/2" larger than the pipe, trench excavation is considerably less compared with concrete—again, saving time and money.

## Field Installation Instructions

The spigot and bell ends must be cleaned of any dirt or debris prior to assembly. The fluted gasket shall be placed in the first corrugation with the lower flute nearest the end of the pipe. The bell & gasket shall be thoroughly lubed just before stabbing in the bell. Do not place hands, fingers, or any other body parts between bell and spigot during assembly. If it is necessary to pull the joint apart, the bell, spigot and gasket shall be inspected and cleaned of any dirt or debris prior to re-stabbing.

## Corrugated Metal Pipe Bell and Spigot Joint Specification

The joints shall be of such design and the ends of the corrugated metal pipe sections so formed that the pipe can be laid together to make a continuous line of pipe. The joint shall be made from the same material as the pipe and shall prevent infiltration of the fill material.

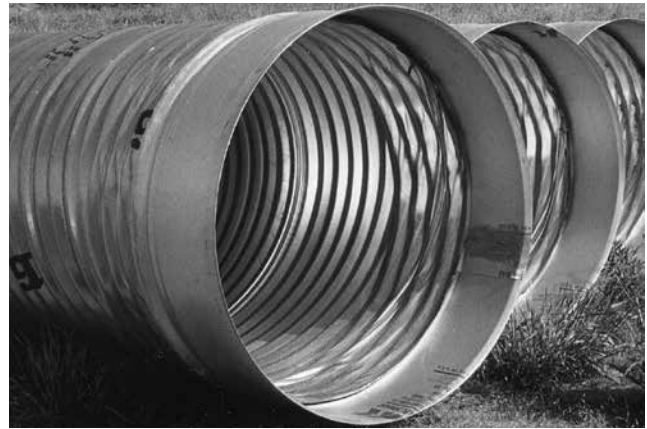

## Bell and Spigot Coupling System for CMP

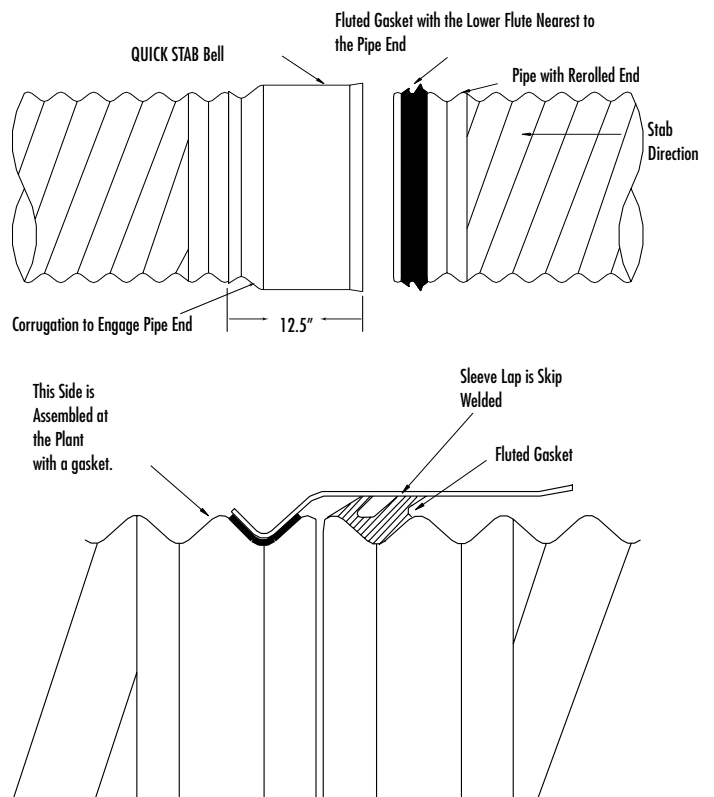

The Bell and Spigot joint is available on ULTRA FLO® and 2 2/3" x 1/2" corrugation in 15" through 60" diameter.

# End Sections

## Easily installed, easily maintained culvert end treatments for corrugated metal pipe, reinforced concrete pipe and HDPE Pipe

Contech End Sections provide a practical, economical and hydraulically superior method of finishing a variety of culvert materials.

The lightweight, flexible metal construction of Contech End Sections creates an attractive, durable and erosion-preventing treatment for all sizes of culvert inlets and outlets. They can be used with corrugated metal pipe having either annular or helical corrugations, and both reinforced concrete and plastic pipes. End sections can be salvaged when lengthening or relocating the culvert.

Standard End Sections are fabricated from pregalvanized steel. For added corrosion resistance, Aluminized Type 2 or Aluminum End Sections are available in smaller sizes. Special End Sections for multiple pipe installations may be available on a specific inquiry basis.

### Better hydraulics

Flow characteristics are greatly improved by the exacting design of Contech End Sections. Scour and sedimentation conditions are improved, and headwater depth can be better controlled. Culverts aligned with the stream flow and finished with Contech End Sections generally require no additional hydraulic controls.

### Improved appearance

Contech End Sections blend well with the surroundings. The tapered sides of an End Section merge with slope design to improve roadside appearance. Unsightly weeds and debris collection at the culvert end are reduced.

### Economical installation

Lightweight equipment and simple crew instructions result in smooth and easy installation. Contech End Sections are easily joined to culvert barrels, forming a continuous, one-piece structure. For easiest installation, End Sections should be installed at the same time as the culvert. Installation is completed by tamping soil around the End Section.

### Low maintenance

Contech End Sections reduce maintenance expense because their tapered design promotes easier mowing and snow removal. There is no obstruction to hamper weed cutting.

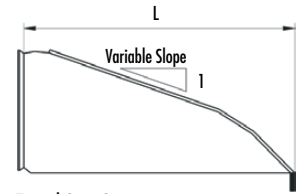

Typical Cross Section

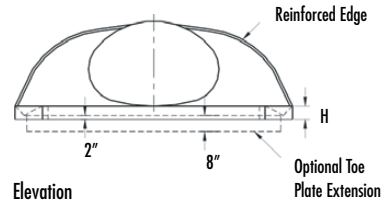

Elevation

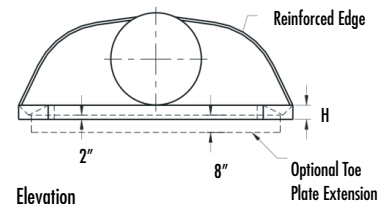

Elevation

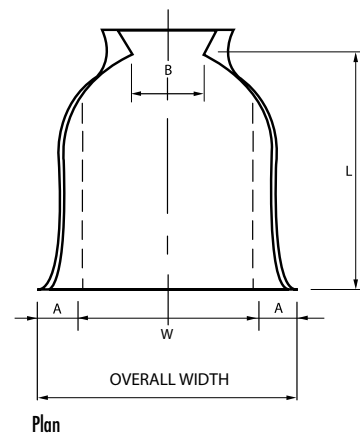

Plan

### Notes for all End Sections:

1. All three-piece bodies to have 12 GA sides and 10 GA center panels. Multiple panel bodies to have lap seams which are to be tightly joined by galvanized rivets or bolts.
2. For 60" through 84" sizes, reinforced edges are supplemented with stiffener angles. The angles are attached by galvanized nuts and bolts. For the 66" and 72" round equivalent pipe-arch sizes, reinforced edges are supplemented by angles. The angles are attached by galvanized nuts and bolts.
3. Angle reinforcements are placed under the center panel seams on the 66" and 72" round equivalent pipe-arch sizes.
4. Toe plate is available as an accessory, when specified on the order, and will be same gage (GA) as the End Section.
5. Stiffener angles, angle reinforcement, and toe plates are the same base metal as end section body.
6. End sections with 6:1 and 4:1 slopes are available in 12" through 24" diameters.
7. Actual dimensions may vary slightly.
8. During manufacturing, a slight invert slope may result along the length of the end section to be accommodated in the field.

End Sections for Round Pipe (2-2/3" x 1/2", 3" x 1" and 5" x 1")							
Approximate Dimensions, Inches <sup>(7)</sup>							
Pipe Diameter	Gage	A (+/- 1")	B (Max)	H (Min)	L (+/- 2")	W (+/- 2")	Overall Width (+/- 4")
12	16	6	6	6	21	24	36
15	16	7	8	6	26	30	44
18	16	8	10	6	31	36	52
21	16	9	12	6	36	42	60
24	16	10	13	6	41	48	68
30	14	12	16	8	51	60	84
36	14	14	19	9	60	72	100
42	12	16	22	11	69	84	116
48	12	18	27	12	78	90	126
54	12	18	30	12	84	102	138
60	12/10	18	33	12	87	114	150
66	12/10	18	36	12	87	120	156
72	12/10	18	39	12	87	126	162
78	12/10	18	42	12	87	132	168
84	12/10	18	45	12	87	138	174

End Sections for Pipe-Arch (2-2/3" x 1/2")								
Approximate Dimensions, Inches <sup>(7)</sup>								
Round Equivalent	Span x Rise (in.)	Gage	A (+/- 1")	B (Max)	H (+/- 1")	L (+/- 2")	W (+/- 2")	Overall Width (+/- 4")
15	17 x 13	16	7	9	6	19	30	44
18	21 x 15	16	7	10	6	23	36	50
21	24 x 18	16	8	12	6	28	42	58
24	28 x 20	16	9	14	6	32	48	66
30	35 x 24	14	10	16	6	39	60	80
36	42 x 29	14	12	18	8	46	75	99
42	49 x 33	12	13	21	9	53	85	111
48	57 x 38	12	18	26	12	63	90	126
54	64 x 43	12	18	30	12	70	102	138
60	71 x 47	12/10	18	33	12	77	114	150
66	77 x 52	12/10	18	36	12	77	126	162
72	83 x 57	12/10	18	39	12	77	138	174

End Sections for Pipe-Arch (3" x 1" and 5" x 1")								
Approximate Dimensions, Inches <sup>(7)</sup>								
Round Equivalent	Span x Rise (in.)	Gage	A (+/- 1")	B (Max)	H (+/- 1")	W (+/- 2")	L (+/- 2")	Overall Width (+/- 4")
48	53 x 41	12	18	25	12	90	63	126
54	60 x 46	12	18	34	12	102	70	138
60	66 x 51	12/10	18	33	12	116	77	152
66	73 x 55	12/10	18	36	12	126	77	162
72	81 x 59	12/10	18	39	12	138	77	174
78	87 x 63	12/10	20	38	12	148	77	188
84	95 x 67	12/10	20	34	12	162	87	202
90	103 x 71	12/10	20	38	12	174	87	214
96	112 x 75	12/10	20	40	12	174	87	214

**Contech End Sections attach to corrugated metal pipe, reinforced concrete and plastic pipe.**

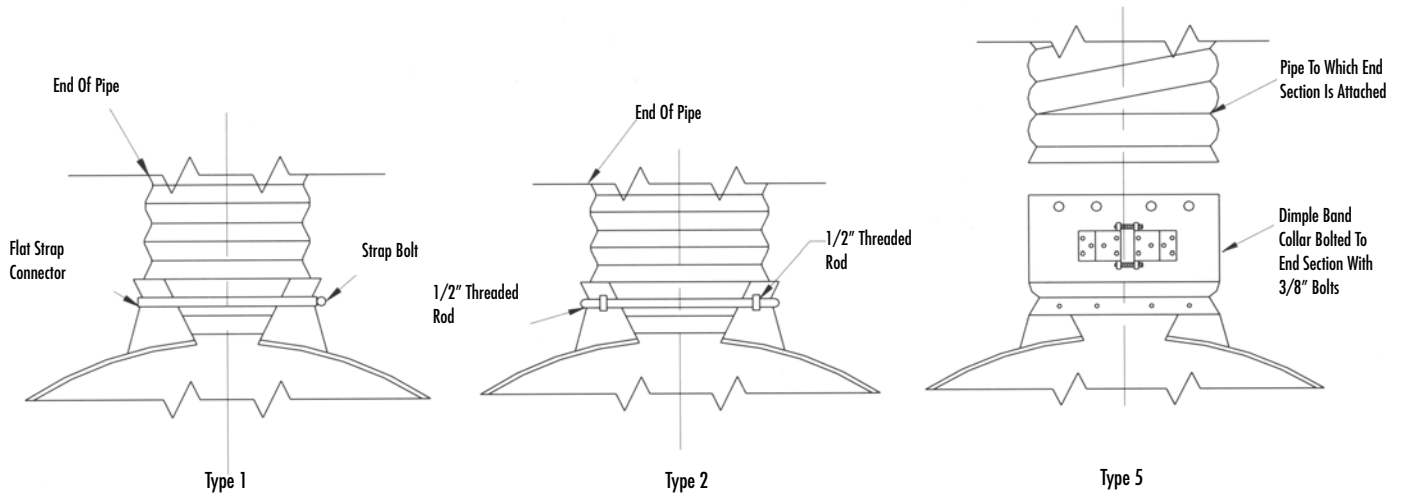

**Note:** The Type 3 connection is not illustrated. This connection is a one-foot length of pipe attached to the end section.



Multiple End Section on Round CSP



End Sections are available for CSP Pipe-Arch



Contech End Sections are often used on concrete pipe. They can be used on both the bell and spigot end.



Low-slope End Sections—Contech manufactures 4:1 and 6:1 low-slope End Sections for corrugated metal pipe. This photo shows the optional field-attached safety bars.

Contech® Engineered Solutions provides innovative, cost-effective site solutions to engineers, contractors and developers on projects across North America. Our portfolio includes bridges, drainage, erosion control, retaining wall, sanitary sewer and stormwater management products.

**For more information, call one of Contech’s Regional Offices located in the following cities:**

**Ohio (Corporate Office) 513-645-7000**

- California (Roseville) 800-548-4667
- Colorado (Denver) 720-587-2700
- Florida (Orlando) 321-348-3520
- Maine (Scarborough) 207-885-9830
- Maryland (Baltimore) 410-740-8490
- Oregon (Portland) 503-258-3180
- Texas (Dallas) 972-590-2000

**www.ContechES.com | 800-338-1122**

NOTHING IN THIS CATALOG SHOULD BE CONSTRUED AS A WARRANTY. APPLICATIONS SUGGESTED HEREIN ARE DESCRIBED ONLY TO HELP READERS MAKE THEIR OWN EVALUATIONS AND DECISIONS, AND ARE NEITHER GUARANTEES NOR WARRANTIES OF SUITABILITY FOR ANY APPLICATION. CONTECH MAKES NO WARRANTY WHATSOEVER, EXPRESS OR IMPLIED, RELATED TO THE APPLICATIONS, MATERIALS, COATINGS, OR PRODUCTS DISCUSSED HEREIN. ALL IMPLIED WARRANTIES OF MERCHANTABILITY AND ALL IMPLIED WARRANTIES OF FITNESS FOR ANY PARTICULAR PURPOSE ARE DISCLAIMED BY CONTECH. SEE CONTECH’S CONDITIONS OF SALE (AVAILABLE AT WWW.CONTECHES.COM/COS) FOR MORE INFORMATION.

