



## GlasPave® Paving Mats Outperform Others in Innovative Overlay Test

### BACKGROUND

Evaluating asphalt interlayers' reflective crack performance in the field is typically an extremely time-intensive process, sometimes taking years to complete. Numerous studies and experiments, conducted by academia, government agencies, and the industry, have failed to create a reliable and inexpensive method.

### OBJECTIVE

The Texas Transportation Institute (TTI) performs overlay testing on its own asphalt mixtures to quantify the fracture performance of its asphalt. TTI sought to create an industry testing standard to uniformly measure and test various types of asphalt interlayers. TTI's monotonic overlay test provides a method that not only equally measures all types of asphalt interlayers, regardless of type or manufacturer, but also offers:

- ▶ An inexpensive and quick method
- ▶ Excellent repeatability
- ▶ Ease of sample preparation
- ▶ A uniform process that can be used to quickly test any asphalt interlayer in any type of asphalt mixture

### DESCRIPTION OF THE STUDY

Overlay testing provides a quick way to measure how a given interlayer will improve the crack reflection properties of any asphalt mix. TTI's test uses 6 in. diameter gyratory compacted asphalt samples, 2 ½ in. thick and notched. The sample is created using a 1 in. level up, the interlayer and a 1 ½ in. overlay. The sample is then notched and trimmed prior to testing (Image A).

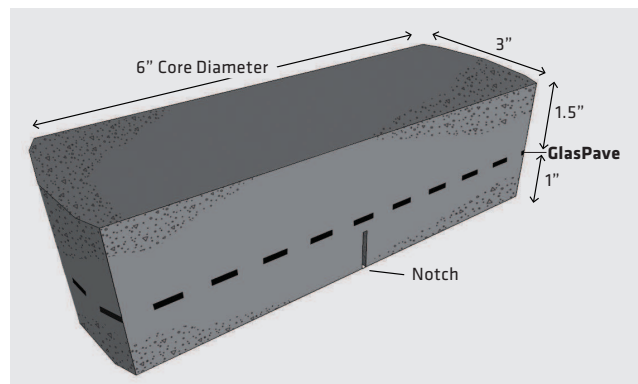

**Image A:** Illustration of asphalt with interlayer sample used in test method.

The test is performed three times for each interlayer with the ultimate tensile stress and the associated strain recorded for each sample. The interlayer test results are then averaged and compared to the test results of the control sample (Figure 1 and see calculation steps on next page).

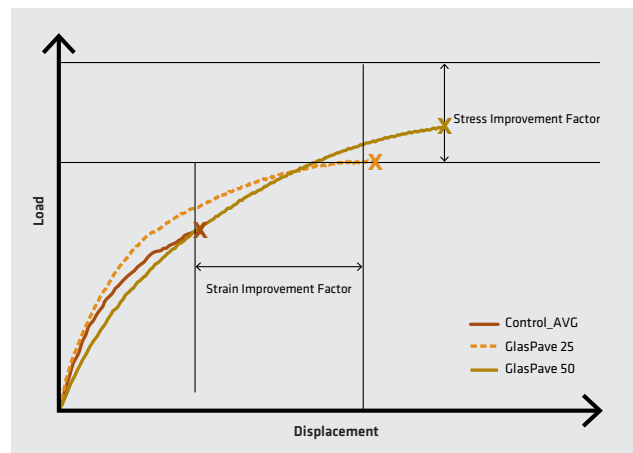

**Figure 1:** As illustrated above, the use of GlasPave Paving Mats improve the tensile properties of the asphalt control mixture.

The improvement in tensile stress and strain versus the control is calculated using the following steps.

► **Stress Improvement Factor ( $\sigma/\sigma_c$ )**

Where:

$\sigma_i$  is ultimate stress with the interlayer

$\sigma_c$  is ultimate stress of the control

► **Strain Improvement Factor ( $\epsilon_i/\epsilon_c$ )**

Where:

$\epsilon_i$  is strain at ultimate stress with the interlayer

$\epsilon_c$  is strain at ultimate stress of the control

► **Stress Improvement Factor x Strain Improvement Factor = Interlayer Crack Mitigation (ICM) Factor**

By using the Stress Improvement Factor and the Strain Improvement Factor, one can calculate the improvement in the asphalt's ability to resist reflective cracking, which is expressed as the ICM Factor. As shown below (Figure 2), GlasPave Paving Mats outperformed the other paving fabrics and mats tested.

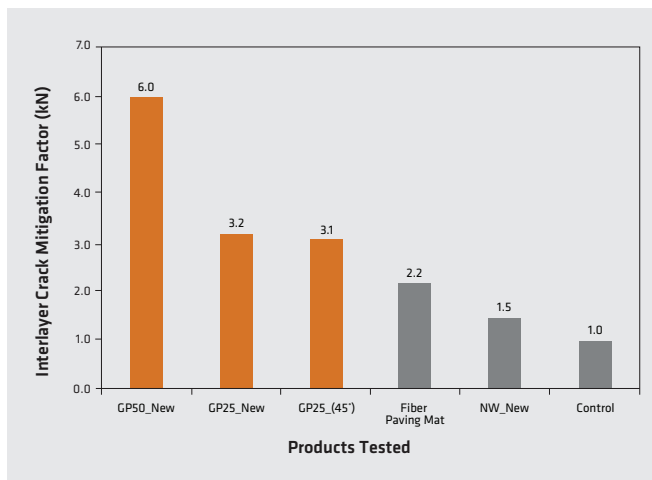

**Figure 2:** GlasPave Paving Mats interlayer crack mitigation factors versus common paving fabrics and mats.

## CONCLUSIONS

- GlasPave25 outperformed conventional AASHTO paving fabrics and paving mats by as much as two times
- GlasPave50 surpassed conventional AASHTO paving fabrics and paving mats by as much as four times
- Off-angle performance of GlasPave Paving Mats is equivalent to the machine direction performance
- There are clear product performance differences between GlasPave Paving Mats and the most common paving fabrics and paving mats

## EXPERIENCE YOU CAN RELY ON

Tensar International Corporation (Tensar), the leader in geosynthetic soil reinforcement and stabilization, offers a variety of solutions for foundation and roadway applications. Our products and technologies, backed by the most thorough quality assurance practices, are at the forefront of the industry. Our support services include site evaluation, design consulting and site assistance.

For innovative solutions to your site work challenges, rely on the experience, resources and expertise that have set the industry standard for more than three decades.

For more information on the GlasPave Paving Mats or any of the Tensar Systems, call **800-TENSAR-1**, visit [www.tensarcorp.com](http://www.tensarcorp.com) or e-mail [info@tensarcorp.com](mailto:info@tensarcorp.com).

# Tensar®

Tensar International Corporation  
2500 Northwinds Parkway  
Suite 500  
Alpharetta, GA 30009  
800-TENSAR-1  
[tensarcorp.com](http://tensarcorp.com)



Exclusive distributors in the Americas for:

GlasPave® is a registered trademark of Saint-Gobain ADFORS. GlasPave® is distributed in the United States of America, Canada and certain other countries by Tensar International Corporation. Inasmuch as Saint-Gobain ADFORS and Tensar have no control over installation design, installation workmanship, accessory materials, or conditions of application, Saint-Gobain ADFORS and Tensar do not warrant the performance or results of any installation or use of GlasPave®. This warranty disclaimer includes all implied warranties, statutory or otherwise, including the warranty of merchantability and of fitness for a particular purpose.

©2015, Tensar International Corporation